

900 MHz Cordless Telephone with Caller ID

Featuring Clarity® Power™ Technology

Clarity 430 User Guide

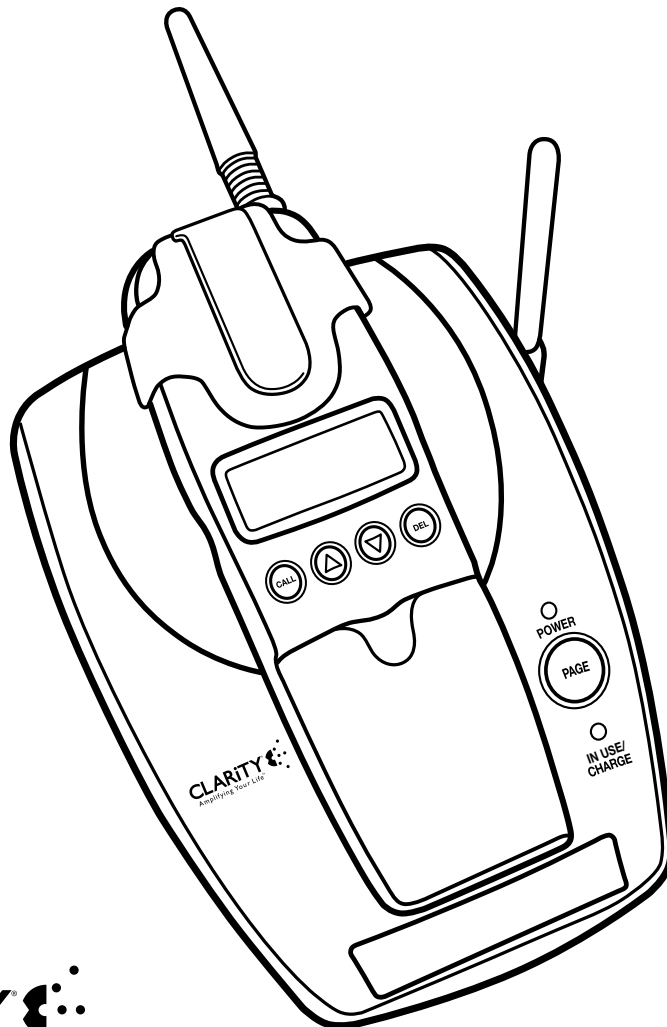

Table of Contents

Safety Instructions	3	Answering a Call	16
Features	5	Temporary Tone	16
Getting Started	8	Visual Ringers	16
Choosing a Location	8	Flash	16
Installation	8	Mute	16
Battery Installation	10	Redial/Pause	16
Handset Battery Charging	10	LCD Display Screen	17
Low Battery	10	Lighted Key Pad	17
Battery Life	10	Base Lights	17
Headset Jack	11	Page/Handset Locator	17
Belt Clip	11	Channel Operation	17
Hearing Aid Compatibility	11	Security Code	17
Quick Reference Guide	11	Memory Storage	18
Feature Set Up	12	Memory Storage Locations	18
Handset	12	Storing Numbers into Memory	18
Set Up Mode	12	Dialing From Memory	18
Clarity Power Technology	14	Editing Numbers in Memory	18
Boost Clarity Power On/Off	14	Deleting Numbers from Memory	18
Volume Control	14	Caller ID Operations	19
Handset Ringer	14	Viewing Call List	19
Telephone Base	14	Placing a Call from the List	20
Boost On/Off	14	Deleting Entries	20
Pulse/Tone	15	Call Waiting	20
Ringer Volume	15	Care	21
Ringer Style	15	Trouble Shooting	21
Telephone Operations	16	Regulatory Compliance	23
Placing a Call	16	Warranty and Service	26

Important Safety Instructions

When using your telephone equipment, basic safety precautions should always be followed to reduce the risk of fire, electric shock and injury to persons including the following:

1. Read and understand all instructions.
2. Follow all warnings and instructions marked on the telephone.
3. Do not use this telephone near a bath tub, wash basin, kitchen sink or laundry tub, in a wet basement, near a swimming pool or anywhere else there is water.
4. Avoid using a telephone (other than a cordless type) during a storm. There may be a remote risk of electrical shock from lightning.
5. Do not use the telephone to report a gas leak in the vicinity of the leak.
6. Unplug this telephone from the wall outlets before cleaning. Do not use liquid cleaners or aerosol cleaners on the telephone. Use a damp cloth for cleaning.
7. Place this telephone on a stable surface. Serious damage and/or injury may result if the telephone falls.
8. Do not cover the slots and openings on this telephone. This telephone should never be placed near or over a radiator or heat register. This telephone should not be placed in a built-in installation unless proper ventilation is provided.
9. Operate this telephone using the electrical voltage as stated on the base unit or in the owner's manual. If you are not sure of the voltage in your home, consult your dealer or local power company.
10. Do not place anything on the power cord. Install the telephone where no one will step or trip on the cord.
11. Do not overload wall outlets or extension cords as this can increase the risk of fire or electrical shock.
12. Never push any objects through the slots in the telephone. They can touch dangerous voltage points or short out parts that could result in a risk of fire or electrical shock. Never spill liquid of any kind on the telephone.
13. To reduce the risk of electrical shock, do not take this phone apart. Opening or removing covers may expose you to dangerous voltages or other risks. Incorrect reassembly can cause electric shock when the appliance is subsequently used.
14. Unplug this product from the wall outlet and refer servicing to the manufacturer under the following conditions:
 - A. When the power supply cord or plug is frayed or damaged.
 - B. If liquid has been spilled into the product.
 - C. If the telephone has been exposed to rain or water.
 - D. If the telephone does not operate

SAVE THESE INSTRUCTIONS

Important Safety Instructions

normally by following the operating instructions. Adjust only those controls that are covered by the operating instructions. Improper adjustment may require extensive work by a qualified technician to restore the telephone to normal operation.

- E. If the telephone has been dropped or the case has been damaged.
 - F. If the telephone exhibits a distinct change in performance.
15. Never install telephone wiring during a lightning storm.
 16. Never install telephone jacks in wet locations unless the jack is specifically designed for wet locations.
 17. Never touch uninsulated telephone wires or terminals unless the telephone line has been disconnected at the network interface.
 18. Use caution when installing or modifying telephone lines.
 19. Use only the power cord and batteries indicated in the manual. Do not dispose of batteries in a fire. They may explode. Check with local codes for possible special disposal instructions.

Safety Instructions For Batteries

CAUTION: Risk of explosion if battery is replaced by an incorrect type. Dispose of used batteries according to the instructions.

1. Use only the approved battery pack in the handset of your cordless phone.

For Handset Unit: 3.6V 600mAh
NiMH Rechargeable Battery
GP60AAA3BMJ
GPI International Ltd

2. Do not dispose of the battery in a fire as it may explode. Check with local codes for possible special disposal instructions.
3. Do not open or mutilate the battery. Released electrolyte is corrosive and

may cause damage to the eyes and skin. It may be toxic if swallowed.

4. Exercise care in handling batteries in order not to short the battery with conducting materials such as rings, bracelets and keys. The battery or conduction material may overheat and cause burns.
5. Charge the battery (ies) provided with or identified for use with this product only in accordance with the instructions and limitations specified in this manual.
6. Observe proper polarity orientation between the battery pack and the battery charger.

SAVE THESE INSTRUCTIONS

Features

Handset

1. Antenna/Visual Ringer/
New Call Indicator
2. 2.5 mm Headset Jack
3. Key Pad
4. Handset Charging Contacts
5. Channel Button (CH)
6. Talk Button (TALK)
7. Memory Button (MEM)
8. Emergency Memory Storage Buttons
9. Flash Button (FLASH)
10. Mute Button (MUTE)
11. Redial/Pause Button (RD/P)
12. Temporary Tone Button (*)
13. Handset Ringer Off/On
14. BOOST Clarity Power
15. Volume Control

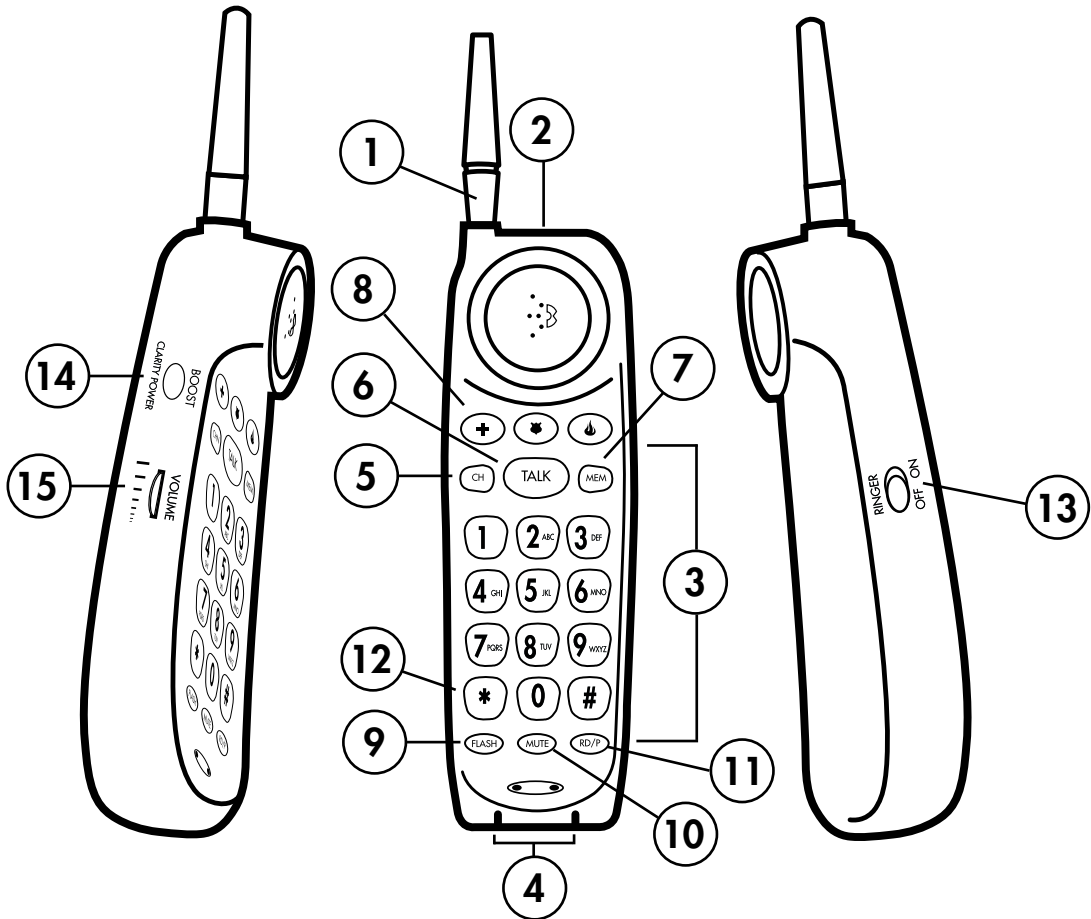

Features

Top of Base/Handset Back

1. Visual Ringer
2. Charging Contacts
3. Base Antenna
4. Power LED (RED)
5. In Use/Charge LED (GREEN/RED)
6. Page
7. Call
8. Scroll Up
9. Scroll Down
10. Delete
11. LCD
12. Belt Clip

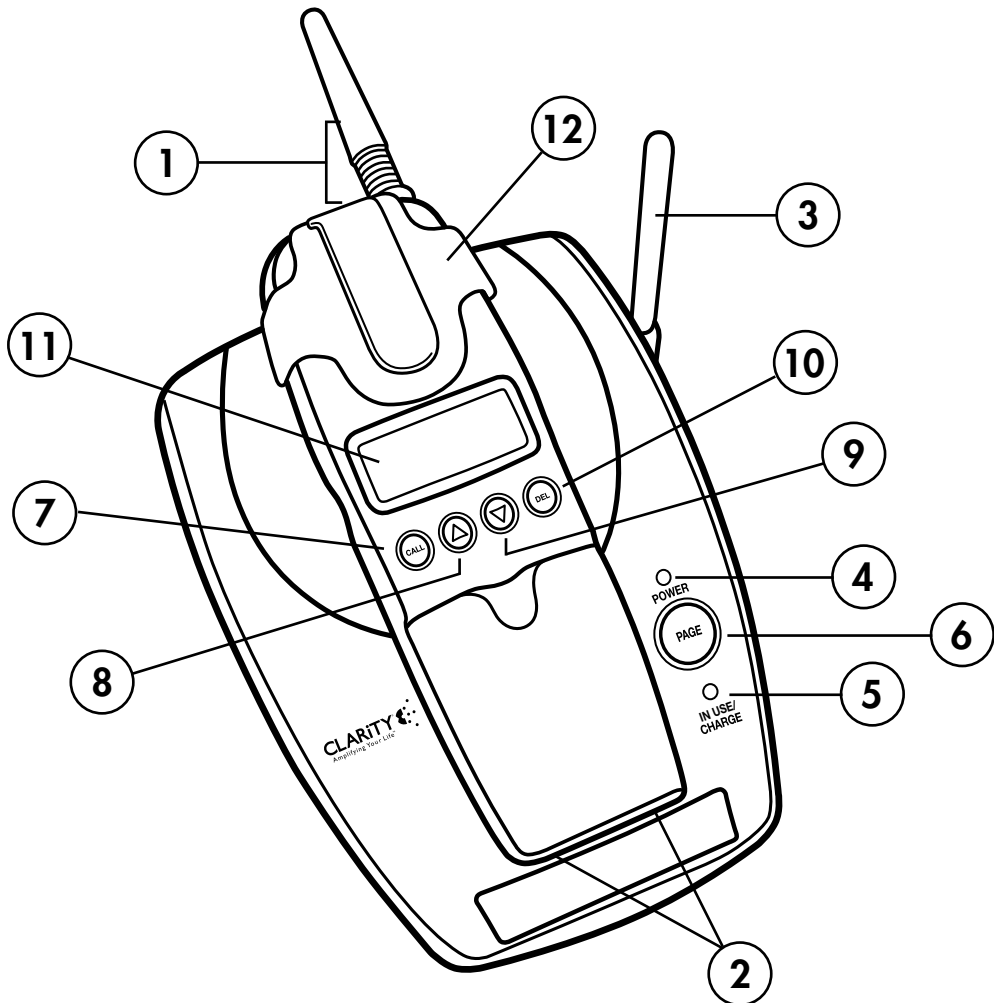

Features

Base Side and End

1. Ringer Off/On
2. Volume Up
3. Volume Down
4. Ring Style
5. Pulse/Tone
6. BOOST On/Off
7. AC (Electrical) Adapter Jack
8. Telephone Line Jack

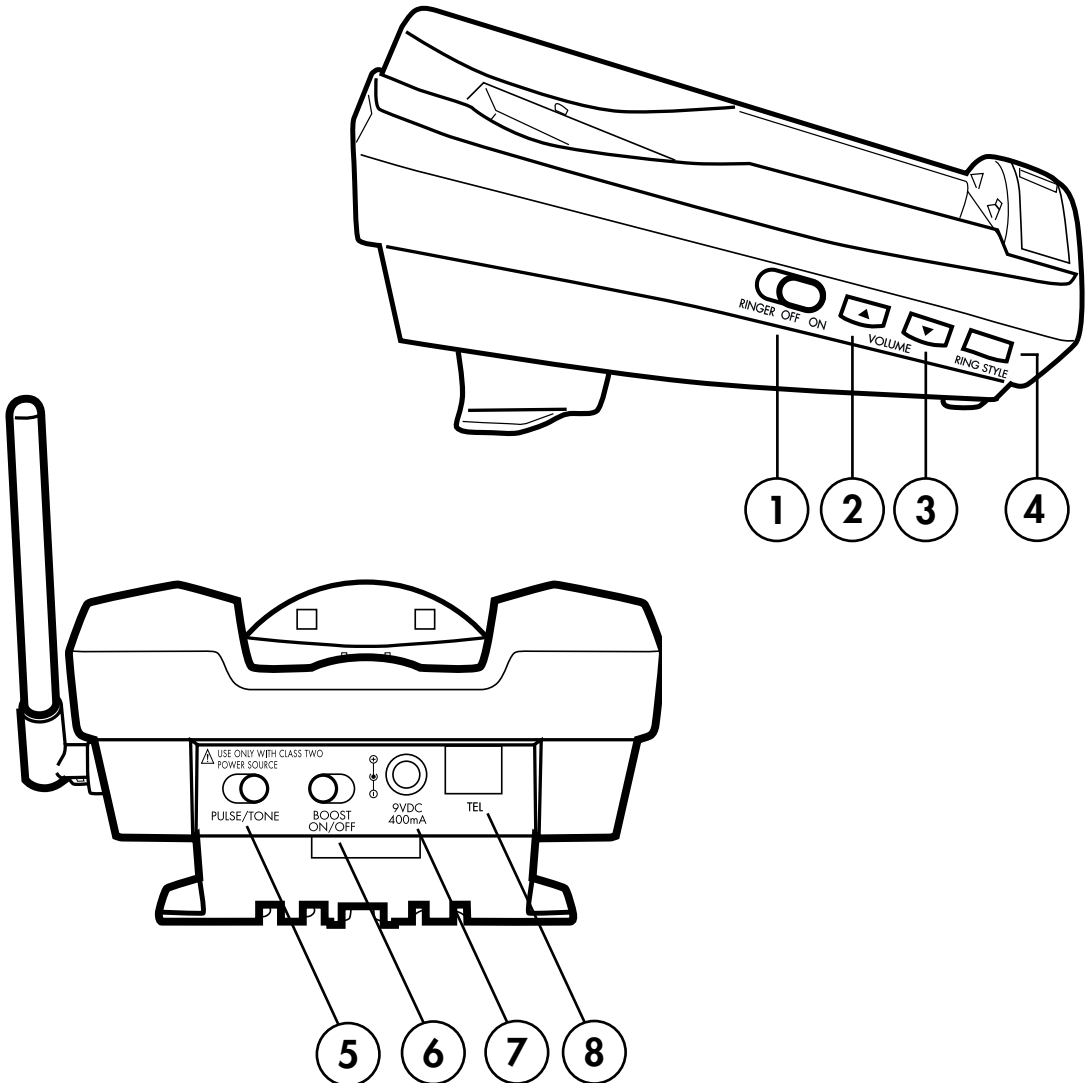

Getting Started

CHOOSING A LOCATION

1. This phone requires a modular phone jack (RJ11C) and a standard 120V AC wall outlet.
2. Plug the AC Adapter directly into outlet.
3. Do not plug other appliances into the same outlet or have outlet controlled by a wall switch.
4. Choose a location that is out of the way of normal activities.

CAUTION: USE ONLY WITH CLASS 2 POWER SOURCE 9V DC, 400MA.

Always connect the AC Adapter to the phone before you connect it to the AC power. When you finish, disconnect the AC power before you disconnect it from the phone.

INSTALLATION

Connecting Your Telephone

Carefully remove your cordless telephone from its box. If there is any visible damage, do not attempt to operate this equipment. Return it to the place of purchase.

Check to be sure that you have all items that come with your telephone. You should have a **HANDSET, BASE UNIT, AC ADAPTER, TELEPHONE LINE CORD, BELT CLIP AND OWNERS MANUAL. A BATTERY** is also included and is located in the battery compartment.

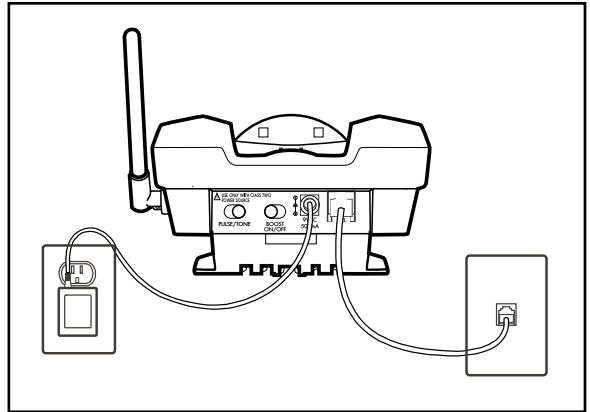

Diagram A: Table/Desktop Installation

If at any time you have questions about your telephone please contact our Customer Service Department at: 1-800-552-3368 or 423-622-7793.

Table/Desktop Installation

1. Plug one end of the supplied modular telephone line cord into the jack marked **TEL** located on the back of the telephone base as shown in Diagram A.
2. Plug the modular telephone line cord's other end into a modular phone jack.
3. Insert the supplied AC Adapter's plug into the jack marked 9V DC 400mA located on the back of the telephone base.
4. Plug the adapter into a standard 120V AC power (electrical) outlet.
5. Lift the base's antenna to a vertical position.

Getting Started

6. Set the TONE/PULSE switch located on the back of the base to correct dialing mode. Please check with your local Phone Company if uncertain of the type of service.
7. Place handset in the cradle to begin initial charging.

WALL MOUNTING INSTRUCTIONS

The base unit may be mounted on a standard wall plate.

1. With the back of the unit facing up insert the supplied mounting bracket's tabs into the base's lower tab slots in then direction of **WALL MOUNT** marked on the bracket, then press down on the brackets clips and insert them into the clip slots.
2. Plug one end of the supplied short modular telephone line cord into the **TEL** jack located on the back of the base of the phone.

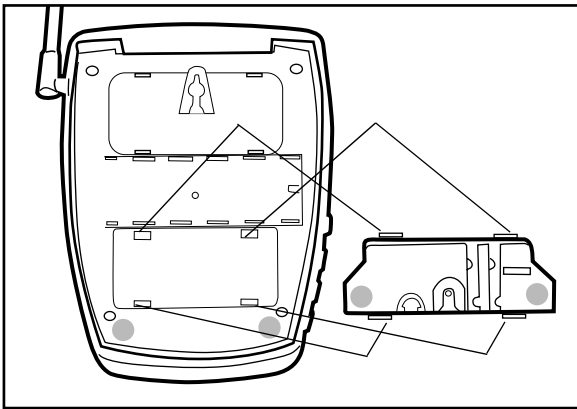

Diagram B: Wall mounting

3. Insert the plug of the AC adapter into the jack marked DC 9V 500mA located on the back of the telephone base.
4. Route the adapter's cord through the narrow groove located on the back of mounting bracket to secure the cord.
5. Plug the short modular telephone line cord into the wall plate jack, then align the mounting bracket's keyhole slots with the wall plate studs and slide the base of the phone downward to secure it on the wall.
6. Plug the adapter into a standard AC power (electrical) outlet.
7. Press and lift out the handset holder tab, turn it around so the narrow tab end extends out and slide back into its slot. This will hold the handset in the cradle when the phone is wall mounted.
8. Lift the base's antenna to a vertical position.
9. Set the Tone/Pulse switch located on the back of the base to correct dialing mode. Please check with your local Phone Company if uncertain of the type of service.
10. Place handset in the cradle to begin initial charging. Remember, you must charge the phone for at least 12 hours before you use the phone for the first time.

Note: Remember, you must charge the phone for at least 12 hours before you use the phone for the first time.

Getting Started

BATTERY INSTALLATION

The C430 uses a 3.6Volt 600mAHr NiMH rechargeable 3 cell (AAA Type) battery that is included with your unit.

HANDSET BATTERY MUST BE CONNECTED BEFORE BEginning INITIAL CHARGING.

To connect battery, remove battery compartment cover and connect battery pack plug into the battery connector as shown in Diagram C.

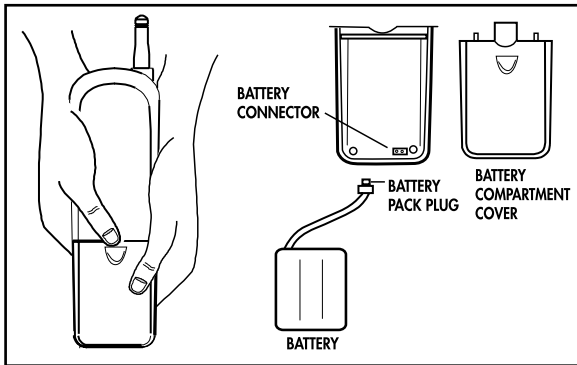

Diagram C: Installing and Connecting Battery

The battery in the handset must be fully charged for 12 hours before using the telephone for the first time.

To Install a New Battery:

1. Remove battery cover
2. Install new battery
3. Connect battery pack
4. Replace battery cover
5. Charge for 12 hours before first use

Handset Battery Charging

1. Place the handset in the base. The **CHARGE LED** on the base will light **RED**.
2. After the batteries are fully charged, check for dial tone by pressing **TALK** on the handset.

Low Battery

When the handset battery gets low, there will be two (2) beeps every thirty (30) seconds and the **TALK** button will flash. If the battery becomes low while you are on a call, you will be disconnected after about two (2) minutes. Terminate the call and recharge the battery. To recharge the battery pack, place the handset in the base.

The battery charge can also be monitored via the battery charge icon. This icon appears while the phone is in the stand by mode and indicates the condition of the batteries.

1. Make sure the contact points are touching and the **CHARGE LED** is lit.
2. Be careful not to short battery with conducting materials such as rings, bracelets and keys.

Battery Life

A fully charged battery provides an average talk time of about four (4) hours, or standby time of about (8) days.

Talk time and standby time may vary depending on operating conditions.

Getting Started

Headset Jack

You can use this telephone hands-free when you install a 2.5 mm headset (purchased separately). To install, plug the headset into the **HEADSET JACK** at the top of the handset.

While in headset mode, the volume of headset is controlled by the telephone and the handset's earpiece and microphone are disconnected.

Ordering a Headset: In the event you wish to purchase a headset for your Clarity 430, please contact Plantronics at 1-800-544-4660 for location near you. We recommend using the Plantronics M110 or M130 headset.

Belt Clip

You may choose to use the optional belt clip with your handset.

1. To attach slide belt clip down onto grooves. Press the tabs on the belt clip into the slots to attach.
2. To remove, lift one side of the belt clip with your thumbnail and push back.

Hearing Aid Compatibility

The handset has a special coil inside of it to couple the sound to hearing aids equipped with T-Switches/T-Coils.

Quick Reference Guide

A pullout quick reference guide is located on the bottom of your C430. It will allow you to quickly reference key operations of your phone and also record the frequently dialed numbers and emergency numbers you may have stored into your telephone.

Feature Set-up

HANDSET

Set Up Mode

NOTE: In Set Up, if there is no input within 30 seconds, the program will default to the last selection in that mode (e.g., Language) and the C430 will return to Standby. If at any time you want to exit Set Up and return to Standby, press **FLASH**.

To enter Setup mode press and hold the **CALL** button for three (3) seconds.

Setting Language

Default: English

1. Press and hold **CALL** for three (3) seconds to enter the Set Up mode. The Caller ID display will read, "**SET LANGUAGE.**"
2. Press **CALL** once to enter the Language selection mode. The current selected language will flash.
3. Press **UP (▲)** or **DOWN (▼)** to scroll through the language options. The displayed language will change to "**FRENCH**" or "**SPANISH.**"
4. Press **CALL** to select the language desired.
5. Press **UP (▲)** or **DOWN (▼)** to advance to the next menu.

Setting the Area Code

1. Press **CALL** to enter the Area Code selection mode. The left most digit in the code sequence will flash. Use the numeric keys on the key pad to enter the desired area code.
2. Press **CALL** to confirm.
3. Press **UP (▲)** or **DOWN (▼)** to advance to the next menu.

Setting Auto Talk

Default: Off

With the auto talk feature **ON** the telephone will automatically connect to a call when lifted from the cradle. With the Auto Talk feature **OFF**, you must press the **TALK** button to connect to an incoming call regardless of the location of the handset.

1. Press **CALL** to enter the auto talk selection mode.
2. Press the **UP (▲)** or **DOWN (▼)** to change the mode.
3. Press call to confirm the selection.
4. Press the **UP (▲)** or **DOWN (▼)** to go to the next menu.

Setting Caller ID On/Off

Default: ON

1. Press **CALL** to enter the auto talk selection mode.
2. Press the **UP (▲)** or **DOWN (▼)** to change the mode.

Feature Set-up

3. Press **CALL** to confirm the selection.
4. Press the **UP (▲)** or **DOWN (▼)** to go to the next menu.

If the **CID** mode is set to off, the **LCD** will display time and date and the display will read "**CID IS OFF**".

Setting Time and Date

Default Time/Date "12:00 AM 01/01"

The time-and-date stamp is automatically updated when the first incoming Caller ID call is received.

If the time setting is lost during a power outage, the clock will flash when power received again.

1. Press **UP** until the display reads, "**TIME/DATE**".
2. Press **CALL** to start changing the date. The display shows the current time and date on the top line, e.g. "12:05AM 12/20" with the month digits flashing.
3. Press **UP (▲)** or **DOWN (▼)** to change the month digits.
4. Press **CALL** once to select. After the month digits are set, the date digits flash.
5. Press **UP (▲)** or **DOWN (▼)** to change the date digits.
6. Press **CALL** once to select. After the date digits are set, the hour digits flash.
7. Press **UP (▲)** or **DOWN (▼)** to change the hour digits.

8. Press **CALL** once to select. After the hour digits are set, the minute digits flash.
9. Press **UP (▲)** or **DOWN (▼)** to change the minute digits.
10. Press **CALL** once to select. After the minute digits are set, **AM/PM** will flash.
11. Press **UP (▲)** or **DOWN (▼)** to for either **AM** or **PM**.
12. Press **CALL** once to select. After **AM** or **PM** is selected, the time/date digits will be blank.
13. Press **CALL** once to display the time/date again or press **UP (▲)** or **DOWN (▼)** to go to the next menu.

Setting Contrast

Default: Level 2

1. Press **CALL** once to enter the Contrast Level selection mode. The current selected level flashes.
2. Press **UP (▲)** or **DOWN (▼)** to change the level.
3. Press **CALL** to select level desired.
4. Press **UP (▲)** or **DOWN (▼)** to advance to the next menu.

Feature Set-up

Clarity Power Technology

With the Clarity Power feature, the high frequency sounds are amplified more than the low frequency sounds so words are not just louder, but clearer and easier to understand.

BOOST Clarity Power On/Off

The C430 has a **BOOST CLARITY POWER** button that controls the loudness of the receiver. Once the **BOOST** button is pressed, an extra level of amplification is added over the entire range of the volume control.

The **TALK** button will light **ORANGE** to indicate the **CLARITY POWER** feature is activated.

WARNING: When the **TALK** button is lit **ORANGE** volume may be at a high level. To protect hearing, lower the volume control to minimum before using.

Volume Control

The dial controls the level of volume the handset and headset receive. The volume dial provides up to 15 dB of volume before the **CLARITY POWER** button is activated. Once the **CLARITY POWER** button is pressed, the Clarity 430 will provide up to 30 dB of gain.

Handset Ringer

Set the switch marked Ringer On/Off located on the side of the handset. The ringer switch must be set to **ON** for the handset to ring.

NOTE: If both handset and base ringer's are set to OFF, the visual ringer will flash to indicate there is an incoming call.

TELEPHONE BASE

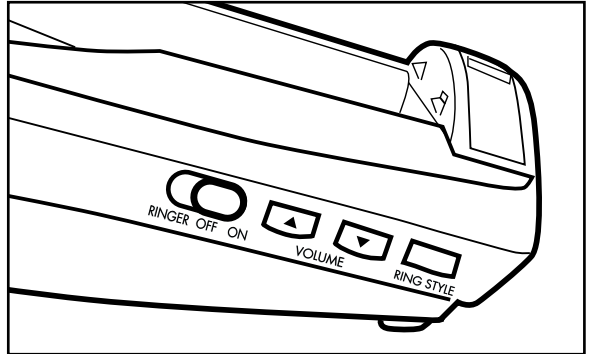

Diagram D: Telephone Base

BOOST ON/OFF Switch

This switch will disable the reset feature of the **BOOST** Clarity Power button as follows:

ON – When the Boost **ON/OFF** switch is set to “**ON**”, the Boost function will be **ON** every time a call starts, and will default to **ON** every time the phone hangs up. During a call, the **BOOST** Clarity Power button can toggle the Clarity Power **ON** or **OFF** according to the user’s needs.

OFF – When the Boost **ON/OFF** switch is set to “**OFF**”, the Boost function (Clarity Power) will be **OFF** every time a call starts, and the user will need to press the **BOOST** Clarity

Feature Set-up

Power button in order to gain the extra level of amplification. If the phone hangs up, the Clarity Power will reset to **OFF**. During a call, the **BOOST** Clarity Power button can toggle the Clarity Power function on or off according to the user's needs.

Pulse/Tone

Slide the switch to the type of telephone service you have; tone for touch-tone service or pulse for rotary dialing.

Ringer Volume

Adjust the volume of ring by pressing the VOLUME UP or DOWN switch until the desired ring volume is achieved. There are six (6) levels of volume available.

Ringer Style

The style of ring or cadence can also be adjusted by pressing the **RING STYLE** button. Six (6) styles are available allowing you to customize your ring. The ringer will sound for 2 seconds while choosing a ringer style, to allow the user to make a choice.

NOTE: If both handset and base ringer's are set to OFF, the visual ringer will flash to indicate there is an incoming call.

Telephone Operations

Placing a Call

1. Press the **TALK** button (TALK button will illuminate **GREEN**) and dial the number you wish to call.
2. To end the call press the **TALK** button or place the handset in the base.

Answering a Call

1. Remove handset from base. You will automatically be connected.
OR
2. Press the **TALK** button.

Refer to **BOOST** Clarity Power and Volume Control for information on adjusting volume controls (Page 14).

Temporary Tone

If you have rotary (pulse) dial service, you can change from pulse to touch tone (tone) during a call.

1. Make phone call and wait until it is connected.
2. Press the * key. Keys pressed after this are sent as tone signals.
3. The phone will automatically reset to rotary (pulse) service after the call ends.

Visual Ringers

Visual ringers are located in both the handset antenna and the base of the telephone. When an incoming call is received, these lights will flash. The handset visual ringer will also stay lit while the phone is in use.

Flash

The **FLASH** button is activated to use custom calling services such as Call Waiting or Three Way Calling. Please contact your local telephone company for information on these services.

Mute

The **MUTE** button allows the user to conduct a private conversation that you do not want the person on the other end to hear. While in the mute mode, the **MUTE** button will illuminate **RED** and the microphone in the handset is disabled. Pressing the **MUTE** button again will disengage the **MUTE** feature.

Redial/Pause

The **RD/P** button operates both the last number redial and the pause feature.

Last Number Redial:

The last number dialed (up to 32 digits) is stored in the redial memory until another number is dialed.

To use this feature:

1. Press the **TALK** button.
2. When you hear the dial tone, press the **RD/P** button.
3. The phone will automatically dial for you.

Pause Feature:

Programming in a pause will cause the phone to wait four (4) seconds before dialing additional numbers. This feature

Telephone Operations

may be used when it is necessary to dial an access code (9, for example) and wait for a second dial tone before you can dial an outside number. Press the **RD/P** button at the required point during the memory storage process to program a pause.

LCD Display Screen

The **LCD** located on the back of the phone will display the number you are dialing and with Caller ID service displays information about the call before you answer. The display also functions as call timer when the handset is off hook or on a call.

Lighted Key Pad

The key pad will light for fifteen (15) seconds after removing the handset from the base. To reactivate the feature while in standby, press the **TALK** or the **MEM** button. To activate while the phone is in use, press any key.

Base Lights

POWER ON – Handset is on a call.

IN USE/ CHARGING ON – When handset is in the base charging, the **LED** will shine **RED** when the handset is on a call the LED will shine **GREEN**.

Page/Handset Locator

To send a page signal from the base to the handset, press the **PAGE** button located on the base of the telephone. A series of rings will sound from the handset.

To locate the handset if it is away from the base, press and hold the **PAGE** button for approximately five (5) seconds. A series of rings will sound. Return the handset to the base or press the **TALK** button to cancel the page.

Channel Operation

The Clarity 430 cordless telephone automatically searches and selects the clearest of 40 channels when it is being used. If interference develops on the line, pressing this button will move to another channel.

Security Code

The security code prevents your cordless phone conversations from being accessed by a phone on a different line. Once the handset battery is fully charged, the handset will automatically select the code from over 65,000 different combinations. The code is changed every time the handset is placed in the cradle.

If you have trouble with placing or receiving calls, a lost security code may be the cause of the problem. When this occurs, the handset can no longer communicate with the base. Reset by placing the handset on the base for 5-10 seconds. If that does not work, unplug the AC adapter from the wall outlet. Disconnect the handset battery for 5-10 seconds, and then reconnect. Place hand-set back on the base and then reinsert the AC adapter.

Memory Storage

Memory Storage Locations

The C430 has ten (10) indirect or two touch memory locations on the telephone (0-9) that can be programmed to dial frequently called numbers of up to 16 digits.

Three (3) Emergency Storage buttons are located on the handset. These storage buttons can be programmed with numbers of up to 16 digits.

Storing Numbers into Memory:

1. Press the **MEM** button.
2. Dial the number you wish to store.
3. Press the **MEM** button again.
4. Press either the emergency button or the number on the key pad that you wish to store the number to.
5. A long beep will indicate the programming process is complete.

Dialing from Memory:

1. Press the **TALK** button.
2. Press the **MEM** button.
3. Press the number on the key pad where the desired number has been stored.
4. The call will automatically dial.

To Dial From Emergency Storage Location:

1. Press the **TALK** button.
2. Press the desired emergency button.
3. The call will automatically dial.

Editing Numbers Stored in Memory:

Replace a stored number by programming a new number in its place.

Deleting Numbers from Memory:

1. Press and release the **MEM** button for (3) three seconds .
2. Enter the location number (0-9) or press one of the three (3) emergency buttons and review the number.
3. Press the **DEL** button to erase the memory. **ERASE MEMO** and the location number will be displayed.
4. Press **DEL** again to confirm.
5. A long beep will indicate the process is complete.

NOTE: During the memory storage process the **TALK** button will flash **GREEN**.

In the event of a power outage, memory is retained of at least six (6) hours.

Caller ID Operations

IMPORTANT: You must subscribe to Caller ID Service from your local telephone company to utilize this feature.

This telephone will automatically display an incoming caller's name and telephone along with the date and time of the call. It will record up to fifty (50) calls and store the data into memory.

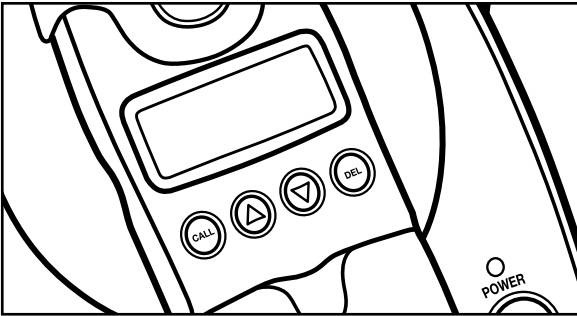

Diagram E: Caller ID Screen

Functions:

CALL: Pressing this button will dial the number displayed and functions as select and save in the set up menu.

SCROLL UP/DOWN: (▲) (▼) Allows for a scrolling review either up or down through the CID list and set up menu.

DELETE: Pressing delete will remove the entry displayed.

The LED in the handset antenna will illuminate **RED** to indicate a new call has been received.

Stand By

In the stand by mode the LCD will display the following information:

- Date/Time
- Battery Status
- Number of received
Example: CALLS ALL =20
- Number of new received calls.
Example: 10 New
- Repeat Icon: **RPT** indicates CID calls that are repeated.

Viewing Call List

When an incoming call is received, the screen will display, the name, number, date and time of call if available.

Blocked Number

NUM BLOCKED will appear if the name and/or number of the caller are blocked.

Unknown Number

NO NUMBER will appear if the name and/or number of the incoming call are not available.

If the telephone number on the Caller ID display is longer than 16 digits the display will toggle between the first half of the number and the second half by pressing the * and # buttons.

Caller ID Operations

The **REPEAT** call icon will light if the C430 receives more than one call from the same number.

There will be message to indicate end of **CID** list.

Placing a call from Caller ID List

1. From stand by use the **UP/ DOWN** arrows to scroll through Call List
2. Select the desired number by pressing **CALL**. Selected number will flash. Use the Up and Down Scroll to view available dialing options (7 digits, 10 digits or 11 digits).
3. Press **CALL** to select the desired call format (see below). The number will stop flashing.
4. Press **CALL** to dial.

When you place calls using Caller ID information, you have three (3) dialing options to select from:

1. 7 digit number (123-4567)
2. 7 digit number plus area code (890-123-4567)
3. 1 plus area code plus 7 digit number (1-890-123-4567)

Deleting Calls from Call list

1. While reviewing the Caller ID, press **DEL** to delete the displayed caller information. The display flashes "**ERASE?**"

2. Press **DEL** to select. The display briefly reads, "**CID ERASED.**" The next Caller ID entry appears automatically or the display reads, "**- NO CALLS -**" if the list is empty.

Phone numbers cannot be deleted while it is in the flashing mode.

Deleting All Caller ID Information

1. While reviewing the Caller ID, hold down **DEL** for three (3) seconds. The display flashes "**ERASE ALL?**"
2. Press **DEL** to select. The display briefly reads "**ALL CID**" and "**ERASED**" and then "**- NO CALLS -**".

At any time, you can press **FLASH** one time to return to standby mode. Or it will return to standby automatically when 30 seconds has elapsed without any keys being pressed.

Call Waiting

When you are on an existing call, you will hear a beep. The **LCD** will display the incoming calls caller ID information. To answer the waiting call, press **FLASH**. The original call will be placed on hold and you will be connected with the waiting call. To return to the original call, press **FLASH**.

If you do not access the waiting call, the caller ID information is transferred into the call list as a viewed call.

Care

The C430 has been designed to give you years of dependable service with a minimum of care.

To ensure the utmost in performance, follow these guidelines in caring for the unit:

1. Avoid dropping or knocking the unit.
2. Dust the unit regularly. Wipe the unit with a soft damp cloth.

Do not use detergents and avoid excess moisture.

3. The C430 is an electrical device. Avoid electric shock by keeping the phone away from water (i.e. bath room, kitchen sink, etc.)

Trouble Shooting

The unit will not operate/no dial tone:

- Verify the TALK Button is lit.
- Verify the AC Adapter is securely plugged into the base and the telephone.
- Verify the telephone line cord is securely plugged into the wall jack and the telephone.
- Make sure the base antenna is in an upright position.
- Make sure the handset battery is fully charged.
- Verify the telephone is in the correct dialing mode, tone (touch) or pulse (rotary).
- Make sure you are in the usable range of the base station.
- Reset the security code by placing the handset in the base for 5-10 seconds.

The phone does not ring when you receive a call:

- Make sure the RINGER switch on the handset and base are set to ON.
- Verify the AC Adapter is securely plugged into the base and the telephone.
- Verify the telephone line cord is securely plugged into the wall jack and the telephone.
- Make sure you are in the usable range of the base station.
- You may have too many extensions on your line. Try unplugging a few devices.

Trouble Shooting

Noise, Static, Interference or Other Calls Heard while Using the Handset:

- Try changing channels.
- Make sure the base antenna is in an upright position.
- Make sure you are in the usable range of the base station.
- Make sure the handset battery is fully charged.
- Try relocating the base unit to another location.
- Make sure the AC Adapter is not plugged into the wall outlet with other appliances.
- Try relocating the base unit to another location.

Phone Will Not Hold Charge:

- Make sure the charging contacts on the handset and base are free of dust and dirt. Clean the contacts with a soft cloth.
- Make sure CHARGE LED on the base is lit when handset is in the cradle.
- If necessary, replace the handset battery. (See Handset Battery Charging)

Difficulty in Placing or Receiving Calls:

- Move closer to the base and try again.
- If moving closer does not work, you may have lost the security code.
- Reset code by placing the handset back on the base for 5-10 seconds. (See Security Code Section)
- Make sure you have selected the correct dialing mode, tone or pulse.
- Make sure the AC Adapter is not plugged into a wall outlet with other appliances. Disconnect for 5-10 seconds then reconnect. Place the handset back on the base and reinsert the AC Adapter.
- Make sure the handset battery is fully charged.

Regulatory Compliance

Part 68 of FCC Rules Information

a) This equipment complies with Part 68 of the FCC rules and the requirements adopted by the ACTA. On the bottom of this equipment is a label that contains, among other information, a product identifier in the format US:AAAEQ##TXXXX. If requested, this number must be provided to the telephone company.

b) A plug and jack used to connect this equipment to the premises wiring and telephone network must comply with the applicable FCC Part 68 rules and requirements adopted by the ACTA. A compliant telephone cord and modular plug, RJ11C USOC, is provided with this product. It is designed to be connected to a compatible modular jack that is also compliant. See installation instructions for details.

c) The REN is used to determine the number of devices that may be connected to a telephone line. Excessive RENs on a telephone line may result in the devices not ringing in response to an incoming call. In most but not all areas, the sum of RENs should not exceed five (5.0). To be certain of the number of devices that may be connected to a line, as determined by the total RENs, contact the local telephone company. For products approved after July 23, 2001, the REN for this product is part of the product identifier that has the format US:AAAEQ##TXXXX. The digits represented by ## are the REN without a decimal point (e.g., 03 is a REN of 0.3). For earlier products, the REN is separately shown on the label.

d) If this telephone equipment causes harm to the telephone network, the telephone company will notify you in advance that temporary discontinuance of service may be required. But if advance notice isn't practical, the telephone company will notify the customer as soon as possible. Also, you will be advised of your right to file a complaint with the FCC if you believe it is necessary.

e) The telephone company may make changes in its facilities, equipment, operations or procedures that could affect the operation of the equipment. If this happens the telephone company will provide advance notice in order for you to make necessary modifications to maintain uninterrupted service.

f) If trouble is experienced with this telephone equipment, for repair or warranty information, please contact Clarity, 1-800-552-3368. If the equipment is causing harm to the telephone network, the telephone company may request that you disconnect the equipment until the problem is resolved.

g) This telephone equipment is not intended to be repaired and it contains no repairable parts. Opening the equipment or any attempt to perform repairs will void the warranty. For service or repairs, call 1-800-552-3368.

h) Connection to party line service is subject to state tariffs. Contact the state public utility commission, public service commission or corporation commission for information.

Regulatory Compliance

i) If your home has specially wired alarm equipment connected to the telephone line, ensure the installation of this telephone equipment does not disable your alarm equipment. If you have questions about what will disable alarm equipment, consult your telephone company or a qualified installer.

j) This telephone equipment is hearing aid compatible.

Customer-Owned Coin/Credit Card Phones:

To comply with state tariffs, the telephone company must be given notification prior to connection. In some states, the state public utility commission, public service commission or corporation commission must give prior approval of connection.

Part 15 of FCC Rules Information

This device complies with Part 15 of the FCC Rules. Operation is subject to the following two conditions: (1) This device may not cause harmful interference, and (2) this device must accept any interference received, including interference that may cause undesired operation.

Your equipment has been tested and found to comply with the limits of a Class B digital device, pursuant to Part 15 of FCC rules. These limits are designed to provide reasonable protection against harmful interference in residential installation.

This equipment generates, uses and can radiate radio frequency energy and, if not installed and used in accordance with the instructions, may cause harmful interference to radio communications. However, there is no guarantee that interference will not occur in a particular installation; if this equipment does cause harmful interference to radio or television reception, which can be determined by turning the equipment off and on, you are encouraged to try to correct the interference by one of the following measures:

1. Where it can be done safely, reorient the receiving television or radio antenna.
2. To the extent possible, relocate the television, radio or other receiver with respect to the telephone equipment. (This increases the separation between the telephone equipment and the receiver.)
3. Connect the telephone equipment into an outlet on a circuit different from that to which the television, radio, or other receiver is connected.
4. Consult the dealer or an experienced Radio/TV Technician for help.

CAUTION: Changes or modifications not expressly approved by the manufacturer responsible for compliance could void the user's authority to operate the equipment.

Regulatory Compliance

Industry Canada Technical Specifications

This product meets the applicable Industry Canada technical specifications.

Before installing this equipment, users should ensure that it is permissible to be connected to the facilities of the local telecommunications company. The equipment must also be installed using an acceptable method of connection. In some cases, the company's inside wiring associated with a single line individual service may be extended by means of a certified connector assembly (telephone extension cord). The customer should be aware that compliance with the above conditions may not prevent degradation of service in some situations.

Repairs to certified equipment should be made by an authorized Canadian maintenance facility designated by the supplier. Any repairs or alterations made by the user to this equipment, or equipment malfunctions, may give the telecommunications company cause to request the user to disconnect the equipment.

Users should ensure for their own protection that the electrical ground connections of the power utility, telephone lines and internal metallic water pipe system, if present, are connected together. This precaution may be particularly important in rural areas.

CAUTION: Users should not attempt to make such connections themselves, but should contact the appropriate electrical inspection authority, or electrician, as appropriate.

The Ringer Equivalence Number is an indication of the maximum number of terminals allowed to be connected to a telephone interface. The termination on an interface may consist of any combination of devices subject only to the requirement that the sum of the Ringer Equivalence Numbers of all the devices does not exceed five.

(The term "IC:" before the certification/registration number only signifies that the Industry Canada technical specifications were met.)

The party responsible for regulatory compliance:

Clarity, A Division of Plantronics, Inc.
4289 Bonny Oaks Drive, Suite 106
Chattanooga, TN 37406
Phone: 1-800-552-3368

Warranty and Service

The following warranty and service information applies only to products purchased and used in the U.S. and Canada. For warranty information in other countries, please contact your local retailer or distributor.

Limited Warranty

Clarity, a division of Plantronics, Inc. ("Clarity") warrants to the original consumer purchaser that, except for limitations and exclusions set forth below, this product shall be free from defects in materials and workmanship for a period of one (1) year from the date of original purchase ("Warranty Period"). The obligation of Clarity under this warranty shall be at Clarity's option, without charge, of any part or unit that proves to be defective in material or workmanship during the Warranty Period.

Exclusions from Warranty

This warranty applies only to defects in factory materials and factory workmanship.

Any condition caused by accident, abuse, misuse or improper operation, violation of instructions furnished by Clarity, destruction or alteration, improper electrical voltages or currents, or repair or maintenance attempted by anyone other than Clarity or an authorized service center, is not a defect covered by this warranty. Telephone companies manufacture different types of equipment and Clarity does not warrant that its equipment is compatible with the equipment of a particular phone company.

Implied Warranties

Under state law, you may be entitled to the benefit of certain implied warranties. These implied warranties will continue in force only during the warranty period. Some states do allow limitations on how long an implied warranty lasts, so the above limitation may not apply to you.

Incidental or Consequential Damages

Neither Clarity nor your retail dealer or selling distributors has any responsibility for any incidental or consequential damages including without limitation, commercial loss or profit, or for any incidental expenses, expenses, loss of time, or inconvenience. Some states do not allow exclusion or limitation of incidental or consequential damage, so the above limitation or exclusion may not apply to you.

Other Legal Rights

This warranty gives you specific legal rights and you may also have other rights which vary from state to state.

Warranty and Service

How to Obtain Warranty Service

To obtain warranty service, please prepay shipment and return the unit to the appropriate facility listed below.

In the United States

Clarity Service Center
4289 Bonny Oaks Drive, Suite 106
Chattanooga, Tennessee 37406

Tel. (423) 622-7793
or (800) 426-3738

Fax: (423) 622-7646
or (800) 325-8871

In Canada

Clarity Service Center
1455 Pitfield Boulevard
Saint-Laurent
Quebec H4S 1G3

Tel: (800) 540-8363
(514) 956-8363

Fax: (514) 956-1825

Please use the original container, or pack the unit(s) in a sturdy carton with sufficient packing material to prevent damage. Include the following information:

1. A proof-of-purchase indicating model number and date of purchase.
2. Bill-to address.
3. Ship-to address.
4. Number and description of units shipped.
5. Name and telephone number of person to call, should contact be necessary.
6. Reason for return and description of the problem.

Damage occurring during shipment is deemed the responsibility of the carrier, and claims should be made directly with the carrier.

